



Operating instructions

**ANTTI AGROSEC
GRAIN DRYER**

408114 (en)

ANTTI-TEOLLISUUS OY

Koskentie 89

FI-25340 Kanunki, Salo

Tel. +358 2 774 4700

Fax +358 2 774 4777

E-mail: antti@antti-teollisuus.fi

www.antti-teollisuus.fi

12-2015

CONTENTS

AGROSEC GRAIN DRYER.....	3
DRYER TYPE.....	3
SAFETY.....	3
PRESENTATION OF THE MACHINE	4
PUTTING THE DRYER MACHINERY IN OPERATION	4
Initial adjustment and checking of the dryer	5
Checking the bottom suction fan – positive pressure dryer.....	6
Checking and initial adjustments of the pre-cleaner.....	6
Operating the pre-cleaner.....	6
Filling the dryer.....	7
Drying	8
Drying partial batches.....	10
Cooling	10
Emptying without the feeder's frequency converter.....	10
Emptying by means of the feeder's frequency converter	11
DRYING TECHNICS	11
Adjusting the temperature	11
Grain variety	12
Grass seeds	12
Turnip rape and rape	12
Drying peas	12
Drying temperature.....	12
ECONOMICAL DRYING.....	13
Thermal economy.....	13
Need to reduce the amount of air	14
Equilibrium moisture content	14
How to reduce the amount of air	15
OTHER FACTORS OF ECONOMICAL DRYING	15
ECONOMIC MAINTENANCE AND OPERATION	16
SERVICE AND WINTER MAINTENANCE	16



AGROSEC GRAIN DRYER

Read the Installation and Instruction Manual carefully before installing the machine and putting it into operation.

This manual is intended for professional farmers. The use of the machine requires normal skills and general knowledge of farming.

The manual deals with the use of a circulating batch dryer. As heat source can be used, for example, an oil-fired dryer heater. Other heat sources may be used in connection with the dryer. Consult the manufacturer for more information.

DRYER TYPE

The manual deals with the use of ANTTI AGROSEC dryer. Refer to the nameplate affixed to the side of the base for information about the type of your dryer. Always notify first the seller and the service personnel of the information in the nameplate to ensure quick assistance in case of malfunction and when ordering spare parts.

SAFETY

The dryer machinery has moving parts that can cause an injury, if all the cover plates and doors are not properly closed, while the machine is in operation!

Never open the doors or covers of the appliances unless you have first ensured that the power supply circuit is disconnected.

NOTE! When opening and closing the covers and doors of the unit, make sure that no other person has opened the inspection or cleaning doors of the unit.



PRESENTATION OF THE MACHINE

- Grain dryers are intended for drying of grain and seeds.
- The drying process comprises four phases:
 1. during filling phase, the elevator transfers the grain from the filling hopper of the dryer into the dryer.
 2. during drying phase, the grain is circulated inside the dryer, and simultaneously, hot air is blown through the grain layers.
 3. during cooling phase, the grain is circulated inside the dryer, and cold outside air is being blown through the grain layers.
 4. the ready-dried and cooled material is transferred by means of an elevator to the storage or to be loaded.
- The pedestal of the dryer comprises the dryer base and the feeder. The drying sections are installed on top of the base.
- The drying unit comprises drying sections with triangular air ducts. The top tanks are stacked on top of the drying unit.
- The volume of the dryer depends on the total number of the sections and top tanks, installed one on top the other.

PUTTING THE DRYER MACHINERY IN OPERATION

To be observed before starting the operation

- the test run must be carried out by the oil burner fitter
- the operation of the safety devices must be tested in practice to ensure their proper operation.
- the oil-tank must contain clean light-oil.
- only clean air is blown or sucked through the heater.

- the shut-off valves in the oil piping are in the open-position.
- check once more that the main switches and the possible safety switches are in the operating position.
- there must be a fire extinguisher near the dryer during drying.
- the slab in the front and at both sides of the suction opening must be clean and you must ensure that, for example, the wind cannot bring debris near the suction opening.

Initial adjustment and checking of the dryer

- set the sluice doors for partial batches into the open-position, and test their operation. If the open and closed positions have not been marked in the levers, do the marking now.
- check that the adjustment of the feeder's speed on the eccentric of the gear motor is not set too high – during first experiments with grain the setting of the eccentric should be about 1.5.
- check that no foreign objects, such as, for example, pieces of board or other loose items, have been left inside the dryer.
- check that the troughs of the feeders are in the closed-position.
- with the feeder troughs in the closed-position, look once more from below that
 - * the troughs are horizontal – and if not,
 - * if necessary, adjust them by shifting the retainer cam of the emptying crank

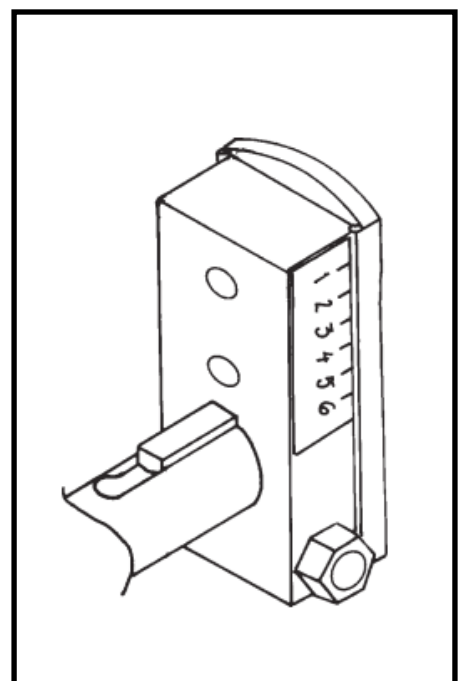

Adjusting the feeder motor eccentric



Checking the bottom suction fan – positive pressure dryer

- check the attachment and, if necessary, strengthen the support
- check that the motor is running in the correct direction
- reduce the air flow

Checking and initial adjustments of the pre-cleaner

- Using a water level, bring the vertical side of the frame part in an exactly upright position. If the pre-cleaner does not stand firmly in the upright position, it must be supported using a separate support bar.
- Before making the grain to flow, the movable weight of the spreading resistance must be transferred to its extreme position, where it lifts the spreading resistance plate.
- While making the grain to flow, the incoming grain flow must be fine-adjusted to the middle of the pre-cleaner's slanting surface.
- The grain flow can be observed through the inspection door on top of the machine. The inspection door shall be covered, for example, with a pane of glass or plexiglass in order not to disturb the air flow.
- The flow of grain to the middle of the slanting surface can be controlled by turning the pre-cleaner around its vertical axis or by changing the direction of the inlet pipe.
- As soon as the grain flows in the middle of the slanting surface, the movable weight shall be transferred into a position, where the thickness of the grain "carpet" is equal across the whole width. The circulation speed of the grain may increase as the drying process proceeds, so do ensure that the grain is not heaped in front of the cleaner.
- Set the air flow lever to the closed-position for the present.

Operating the pre-cleaner

- As soon as the speed of the grain flow inside the machine has been adjusted to normal/desired, the air flow shall be adjusted suitable for each batch to be cleaned.
- Open the grate in the inlet connector, leaving a slight vacuum in the top tank.

- With grain, the air flow setting shall be increased gradually until sharp rattle in the debris pipe reveals that some corns are already moving among the debris. After that, the adjustment lever shall be moved 10–15 mm towards the closed-position (the rattle shall grow fainter). If the sample, taken from the end of the debris pipe, proves appropriate, the air flow may have to be fine-adjusted even further. If the seeds are light, only the latter method is applicable, and in addition, the supervision must be continued until the first batch is finished.

Warning!

If some large object has ended up in the material to be cleaned, the pre-cleaner may be clogged. Ensure always before opening the service doors that the blower motor has stopped also ensuring that no-one else will be able to start it accidentally. A hand, extended inside the inspection door, may reach the rotary blades and be injured severely. When cleaning a clogged pre-cleaner, grain or seeds may easily scatter all over. Clean up immediately the surroundings, especially the stairs, to avoid accidents!

Filling the dryer

Check the position of the divider – the grain must flow into the pipe leading either to the pre-cleaner or the dryer. Also ensure that the feeder troughs stand horizontal in their upper position. It is most convenient to start the drying of the first batch keeping the setting of the feeder's eccentric low, and not increase the feeding rate until the correct values for the other settings have been found. Set the feeding rate low – grain: 1.5–3.0 rape: 1.5–2.0. Start drying the first batch keeping the setting low, and do not increase the feeding rate until you have found the correct values for the other settings.

Start the elevator and the pre-cleaner, and let the grain flow into the elevator by opening the sluice gate or by starting the filling conveyor. When opening the sluice gate on the ascending side of the elevator, the feeding rate very rarely exceeds the lifting capacity of the elevator. When opening the sluice gate on the descending side by about 20 cm, the maximum capacity of the elevator will be applied. If the gate is opened more, the elevator will get clogged. Consult the user manual for the elevator for more detailed instructions.

Ensure that the light for the level guide will be illuminated, as soon as the capacitive sensor is covered by the grain. You can start the heater before the filling is completed, but normally the unit will not be started until the filling has been finished.



Drying

In the beginning, when the grain is moist, the circulation speed may be low. The moisture will evaporate quickly. The heat energy is required for evaporating the water. The temperature of the corn does not rise. It was established during drying experiments that decreasing the circulation speed towards the end also reduced the efficiency (this, combined with the reduced air flow, however, slightly improved the overall efficiency). Increasing the circulation speed improves the efficiency, and even more importantly, balances the moisture content of the drying batch, because the time that the grain stays in the top tank will be shorter. The circulation time of grain in a batch dryer is an hour.

Start the elevator and the pre-cleaner and tip some grain into the hopper. When opening the sluice gate on the ascending side, the feeding rate very rarely exceeds the lifting capacity of the elevator.

Observe the feeding process through the doors in the base. Visually estimated, the amount of grain, running down over both edges of each trough, should be the same (the feeder blades at the sides may feed slightly more than the others). **The grain must not congest inside the bottom cone.** As the drying proceeds, the feeding rate gradually increases.

Set the air flow of the pre-cleaners to as high as possible, however, observing that no full-weight grains end up among debris. Set the pre-cleaner to operate at its maximum efficiency.

For normal drying, the suitable drying air temperature is 65–80 °C. For bread grain, seed grain and malt grain, the upper limit is usually 70 °C, for rape it is 65 °C, and for peas around 50 °C. For fodder grain, it is even possible to apply a temperature up to 100°C. The temperature is kept constant by means of a suitable pair of nozzles. **The burner must operate continuously.** If the temperature limiter occasionally is cooling (=stops the burner), the burner's main nozzle is too large or the pressure of the burner is too high.

Take a few more measurements in the cleaning openings at the inlet side of the air duct to define the temperature of the drying air, or at least, feel the duct with your hand on opposite sides. Usually, the air duct side opposite to the burner, is warmer.

Adjust the air flow from the heater's suction opening so that no grains of normal weight will fly to the outlet end. For rape slight "over flight" is allowed.

Keep an eye on how the drying proceeds. Measure the moisture content from time to time. As soon as the desired moisture content for storing (preferably under 14 %) is reached, lower the setting of the outlet air temperature to the current measured value, which makes the signal light for the burner go out (indicating that the burner has stopped). The setting of the outlet air channel thermostat is now left in a position, that the next time, when you will be drying same kind of grain under roughly same kind of conditions, the automation system will be able to cut off the drying process as soon as the same moisture content percentage has been reached. Write down the setting of the outlet air temperature (at the end of the drying process) and the outside air temperature. After you have written down notes from several drying batches, you can utilize these later and define even more precise cut-off settings of temperature for the drying automation.

In vacuum dryers, replacement air may be conducted into the base cone by removing the cover plate of the cone, indicated by the arrow.

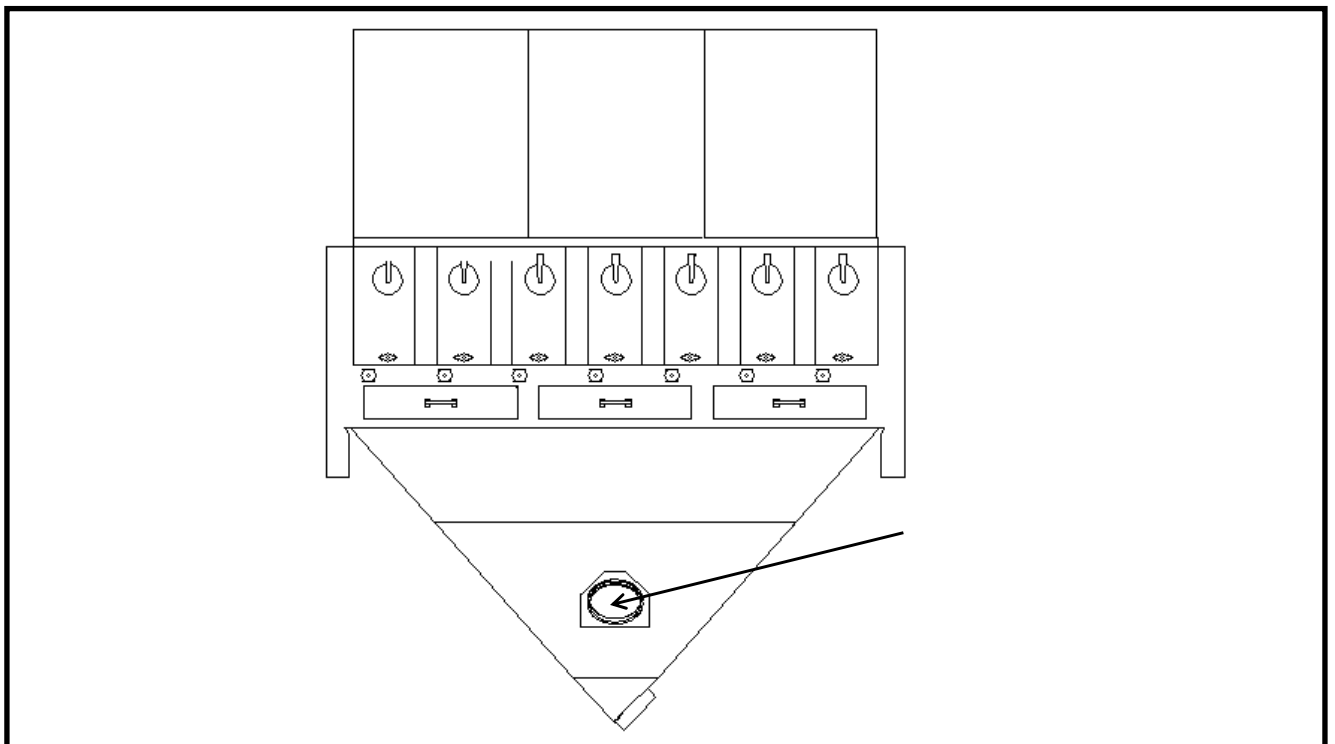



Drying partial batches

Set the sluice gates for partial batches of the drying sections (option) in the closed-position. During drying there must be a layer of grain, appr. 0.5 m thick, on the drying sections. If the layer is thinner than this, the sluice gates of the drying section must be closed in such a manner that the sections that are in use will be covered by a layer that is 0.5 m thick. Check the outlet air channel for occurrence of any overflight of grains, and if necessary, adjust the air flow. Observe, that the drying automation is less accurate, when partial batches are being dried.

It is also possible to apply an automated solution for drying partial batches. Antti Agrosec Optivol automated drying of partial batches (option) automatically optimizes drying of partial batches.

The motorised Optivol, that is based on accurate sensor technology, controls the sluice gates for partial batches. This product is described in greater detail in the Assembly and Operating Manual for Optivol.

Cooling

After the drying, the grain must be properly cooled. A cooling process, taking less than an hour, may only be applied if the weather is cold. If the dryer has more top tanks than drying sections, the time required for cooling will be longer. During the cooling phase, the moisture content of the grain may still drop slightly, but while in the storage, it will resume due to evening out. It pays to measure the moisture content of the grain also after the cooling. Depending on the size of the dryer, during cooling the circulation time of the drying batch may be from one to two hours. Estimate the need to change the feeding rate setting for the next batches taking into account that the entire grain volume must have time to circulate inside the dryer at least one full round. (To measure the circulation time in the most reliable way, empty the dryer at the circulation speed and measure the time).

Emptying without the feeder's frequency converter

Make the grain flow away from the dryer using the divider. Start the elevator, and turn the middle emptying crank of the feeder into the emptying position. Open slowly the sluice gate of the elevator, without exceeding the elevator's capacity (easiest means to monitor the elevator's load rate is to use a loading meter (option)). Mark the sluice gate's position for the next emptying times. Turn the other emptying troughs down. Finally, clatter the dryer empty by swinging the emptying cams.

Emptying by means of the feeder's frequency converter

Make the grain flow away from the dryer using the divider. Start the elevator, and open slowly its sluice gate, without exceeding the elevator's capacity (easiest means to monitor the elevator's load rate is to use a loading meter (option)). Empty the dryer by increasing the feeder's feeding rate.

Consult the control centre manual for instructions for adjusting the feeding rate.

DRYING TECHNICS

During the drying process, you will face a lot of issues, that you should familiarise yourself with in advance. Correct settings are important when drying grain. The output, efficiency etc. can be affected in many ways. Changing the settings becomes necessary when the conditions change. It pays to follow closely the operation of your new dryer during the first year of operation, and write down its various settings to enable efficient and economical drying later on.

Adjusting the temperature

The primary means of raising the temperature is to increase the oil flow. In the 2-stage burner the auxiliary nozzle will burn intermittently as long as additional heat energy is required. If these nozzles, not even together, are able to maintain the desired temperature, increase the feeding pressure or change the nozzles to larger ones. **These measures, however, are applicable only within the limits for the maximum oil flow allowed for the burner.** Consult the heater's manual for detailed instructions.

As the weather gets colder, you may also need to apply other methods to adjust the drying temperature. The next means of raising the temperature (when the maximum allowed oil flow is in use) is to throttle the suction air flow so that the desired drying air temperature will be achieved. The air flow is reduced by means of a manual adjuster. Throttling of the air flow to the dryer heater must always be done in the suction air pipe.

If necessary, the constant temperature automation, available as an option, reduces the air flow automatically. Consult the control centre manual for more information about the constant temperature automation.



Grain variety

The setting of the thermostat and the outlet air temperature slightly vary from variety to variety. If the outlet air temperature 37–38 °C corresponds to the moisture content of 14 % on wheat, the corresponding value for 2-row barley is 38–39 °C, for 6-row barley and oat 34–35 °C, and for rape 32–33 °C (moisture content 9 %). The values may vary from year to year, but their order does not change.

Grass seeds

Drying grass seeds requires special arrangements. Tip grain into the filling hopper, keeping pace with the elevator. Moist seeds arch easily. The pre-cleaner shall not be used. The circulation speed can be the same as with the grain. Throttle the flow of the drying air until the seeds no longer fly out of the drying section to the air channel end. Do not start the burner until the moisture content has dropped under 25 %. After that, you can keep the burner switched on intermittently for 0.5–1 hours. Select the sizes of the nozzles so that the drying air temperature will not rise higher than 40–50 °C. Towards the end, the temperature can be increased by 10 degrees.

Turnip rape and rape

The drying must be commenced immediately after the harvesting. Too high drying air temperature spoils the quality of the oil seeds. The upper limit for the temperature is about 65 °C provided that the circulation time is one hour. The air flow must be limited so that only a non-significant amount of seeds will fly into the outlet air channel (in terms of efficiency, slight "overflight" is, however, useful).

Drying peas

Especially very moist peas are difficult to dry. The drying time must be long to avoid damaging their surface. If the moisture content is over 20 %, the drying air temperature must not exceed 40 °C. Towards the end, the temperature can be increased by about 10 °C, and/or an interval of 24 hours be kept to allow the moisture to even out. If the peas are really moist, we recommend drying them at intervals, keeping the heat on for two hours, and cooling for half an hour.

Drying temperature

The more uniform the drying temperature, the better the automation operates. If the drying air temperature, however, drops, for example, by 5 °C, the cut-off temperature of the outlet air temperature must be decreased by 1.5–2 °C. If this is not observed, the grain will become 1–2 % dryer.



ECONOMICAL DRYING

You must select the operating mode as a compromise between the output and the economy. Applying suitable methods, you will be able to improve them both at the same time.

Thermal economy

The correct drying air temperature is the most important factor impacting both the efficiency and the economy.

Remember the first main rule:

If the amount of air remains the same, raising the temperature will result in higher output and better economy. As the temperature rises, the drying air's ability to absorb steam is multiplied, and the output increases abruptly.

Under normal air pressure, for example, the following amounts of steam correspond to relative humidity of 100 %.

at -20 °C	1	grams of water in m ³ of air
at 0 °C	5	grams of water in m ³ of air
at 20 °C	17	grams of water in m ³ of air
at 30 °C	30	grams of water in m ³ of air
at 50 °C	83	grams of water in m ³ of air
at 60 °C	130	grams of water in m ³ of air
at 70 °C	220	grams of water in m ³ of air
at 75 °C	242	grams of water in m ³ of air
at 100 °C	599	grams of water in m ³ of air

Remember that the lower the relative humidity of the drying air, the faster water evaporates from the corns.

One m³ of the dryer heater's suction air at a temperature of +10 °C, and with relative humidity of 90 %, contains 8 g of water. When it is heated to 70° C, it expands by about 50 %. This amount of air still contains the same 8 g of water, corresponding to relative humidity of 2.7 %. The air almost "sucks" moisture from the corn. Because the relative humidity of the suction air is less significant, hot air drying is efficient and economical even when it is raining.



Need to reduce the amount of air

You may have dimensioned your dryer and dryer heater following the standards, but you still may encounter situations, where the maximum temperature allowed for the heater (maximum nozzle size) will not raise the drying air temperature sufficiently. In this case, you need to throttle the suction opening of the blower so much that the temperature of the drying air will rise. This way you will be able to improve both the dryer's output and economy.

An example of the drying air's ability to absorb steam with the same amount of heat, mixed with different amounts of air:

For warming 10,000 m³ of air from 0 °C to 50 °C is required the same amount of heat than for warming 7,100 m³ of air from 0 °C to 70 °C. Conducting these amounts of air through the grain layers in the dryer, will drop the temperature by the middle of the drying time to about 20 and 27 degrees respectively. Then 10,000 m³ of air at +20 °C can at maximum contain 170 kg of water and 7,100 m³ of air at +27 °C can at maximum contain 188 kg of water. When the air at 0 °C can contain 5 g of water/m³, then with 10,000 m³ of air at 50 °C will go in 50 kg and come out 136 kg (= 86 kg net), and with 7,100 m³ of air at 70 °C will go in 35 kg and come out 150 kg (= 115 kg net).

In practice, the higher the temperature inside the corn during drying, the quicker the water will evaporate causing a pressure difference. This improves the drying efficiency even more than theoretical calculations suggest.

If you are aiming at good economy, you should in certain situations reduce the air amount even if there is no true need to raise the temperature. The aim is to make the air flow through the grain layers sufficiently slowly. If the air is flowing through too fast, it may not have the time to evaporate the same amount of water that it otherwise would be able to absorb. If the air leaves the heater too dry (i.e. too hot), useful heat energy will also be wasted. If you reduce the amount of air, you may need to reduce the oil flow as well (the 2-stage automation does this automatically). This is a concrete way of saving energy.

Equilibrium moisture content

The dryer the grain gets, the slower the water evaporates from the grains. As a result, the relative humidity of the outlet air decreases as the drying proceeds.



How to reduce the amount of air

The amount of suction air for the heater is limited either by a hand-operated air flow shutter, by a motorized constant temperature adjuster (option) or by a frequency converter (option). Usually, the suction air opening must be reduced more than expected. In many cases, reducing the suction opening by 50% only raises the speed of air, but hardly decreases its volume. The suction opening must be reduced so much that the desired rise of temperature shows in the drying temperature gauge.

If you restrict the flow of suction air into the heater too much, the temperature of the drying air will rise too high, and the upper limit thermostat will stop the burner from time to time. Do not let this happen, because then the efficiency of the drying process would drastically decrease, and the dryer heater would be strained clearly more than if the generation of heat was constant. For remedy, increase the air flow or reduce the oil flow.

General note: If you aim at higher capacity, prevent excessive rise of the temperature by increasing the amount of air, and if you aim at improved efficiency, prevent excessive rise of the temperature by reducing the consumption of oil.

OTHER FACTORS OF ECONOMICAL DRYING

Avoid drying too much (for example: for drying from 14 % to 12 %, you will need the same amount of energy as for drying from 19 % to 14 %).

Avoid drying partial batches, because then the capacity will also be partial and the overall efficiency will be reduced.

The settings of the oil burner affect the burning efficiency directly. The adjustments of the burning air must be correct. If you replace the nozzles or adjust the oil pressure, also readjust the burning air flow.

Have the burner serviced at intervals of 1–2 operating seasons. The burner nozzles shall also be replaced at the service. The operator must, however, keep the heater room and the protective net for the suction air opening clean of dust and debris.

Good maintenance of the machinery improves the economy of the operation.

In connection with each annual sweeping, ensure, after closing the sweeping door, that the seal of the door is absolutely tight.

Avoid drying at night, At night the drying always requires more purchased energy than in the daytime.

Make sure that the elevator lifts the grain at full power during the filling and the emptying.

Keep the output setting of the pre-cleaner's blower as high as possible.



ECONOMIC MAINTENANCE AND OPERATION

From time to time, check that the scrapers keep the bucket belt pulleys clean. Also check the bucket belt for tightness. The bucket belt must usually be tightened once (usually after the first operating season). As required, tighten the belt by shortening (see the instructions in the elevator manual).

Check that the inlet and the outlet ends are clean (through the doors). During drying there must be a layer of grain, appr. 0.5 m thick, on the drying sections. If the layer is thinner than this, the sluice gates of the drying section must be closed in such a manner that the sections in use will be covered by a grain layer that is 0.5 m thick.

Note! If the air flow to the drying sections is restricted by means of sluice gates, the air flow must also be throttled at the suction side of the heater blower in order to prevent the positive pressure in the inlet air channel end of a positive pressure heater, or correspondingly, the vacuum at the outlet air channel of a vacuum dryer, from growing too high. The shutters of the air channels must be provided with open-closed stickers as a reminder of their operating positions for the later times of use.

Keep an eye on possible overflight of the grains and the drying temperature. When drying partial batches, the drying automation is less accurate.

In connection with change of variety to be dried, the elevator boot, and the feeder shall be cleaned, and using the dryer heater, air shall be blown into the empty dryer for some time.

SERVICE AND WINTER MAINTENANCE

Lubricate once a week

- elevator bearings
- feeder bearings
- transmission arms of the feeder (2–3 drops of oil)

Annually

- maintenance of the oil burner (assign a specialist)
- checking the oil level in the feeder motor's gearbox and checking for oil leaks

Oil volume in the gearbox:

Gear SK92372.1	0,92 litres	(This gearbox has been installed since 17.3.2015)
Gear SK92372	1,6 litres	(This gearbox was installed until 17.3.2015)



Recommended oil types for gear motors are:

DIN (ISO)/ ambient temperature	BP	CASTROL	FUCHS	KÜBER LUBRICATION	MOBIL	SHELL
ISO VG 220 -10...40°C	Energol GR-XP 220	Alpha EP 220	RENOLIN CLP 220	Klüberoil GEM 1-220 N	Mobilgear 600 XP 220	Omala S2 G 220
ISO VG 220 -10...40°C		Alpha SP 220	RENOLIN CLP 220 Plus			
ISO VG 220 -10...40°C		Optigear BM 220				
ISO VG 220 -10...40°C		Tribol 1100/220				

Winter maintenance

Clean the dryer thoroughly Clean the dryer's bottom cone, the feeders, the air channel ends, and the inner surfaces of the top tanks. Clean the blower of the pre-cleaner.

Leave the cleaning doors open, but close the suction opening of the dryer heater. Close the doors at the elevator boot to prevent the rodents from eating the bucket belt.

If necessary, prevent the birds from gaining access to the air pipes.

